

Promethean Ltd.
Hardware not detected.

This watermark will not be displayed when this application detects Promethean hardware attached to your computer.
This watermark will not be saved with your file.

“My Mac won’t connect to my Promethean board !”

The Problem: Your computer is not detecting your classroom Promethean board.

The three most common problems are:

- No power to board
- An unexplained software issue when starting ActivStudio software
- A bad USB connection between Mac and board

Try these three solutions to resolve this problem

Try and See A Is the board getting power ?
Try and See B Will restarting the Mac fix this?
Try and See C Are my USB cables connected?

The Goal: Make the blue watermark on the board disappear! Computer and board connected!

Try and See A Is the board getting power? 3 easy steps to check.

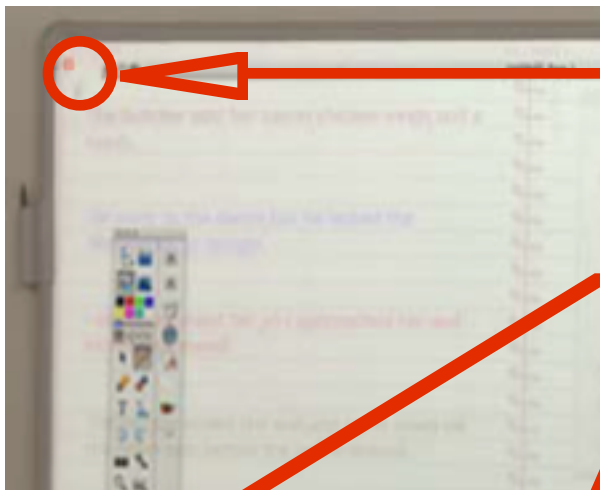

1. Is the Promethean symbol lit in the top-left corner of the board? If it is lit, the board is getting power and you should **go to Try and see B** .

2. The DC Line Connection may have come loose at the connectors. You may have to plug them back together.

3. If the Promethean symbol is not lit, check to see if the power cord for the board is plugged in to the wall.

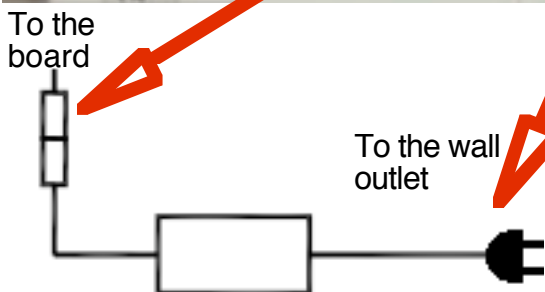

After trying these steps, if the Promethean symbol does not light, **contact your Tech Coach**. You will need some help to get this problem fixed.

Try and See B Will Restarting Mac fix this? 3 easy steps to check.

- Quit and restart the application ActivStudio.
- Quit and shut down your computer.
- Restart your computer and the ActivStudio software.

Still not connected? Go to Try and See C.

Try and See C Are my USB cables connected? 3 easy steps to check.

1. Remove and replace USB cable in computer. Try the other USB slot in your computer too. Does the blue watermark on the board disappear?

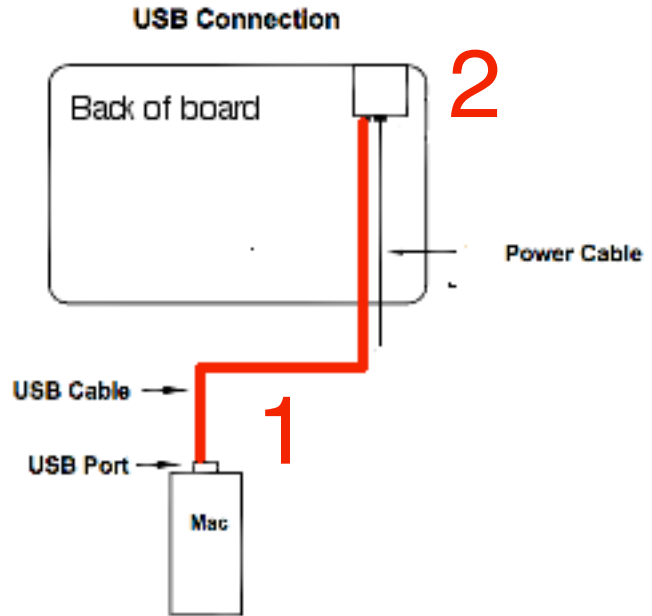

2. Very often, the USB cable has pulled away from the module on the back left side of the board.

a. **Carefully lift** the bottom left end of the board until it clears the hook at the bottom of the board.

b. **Look and reach** behind the board on the top left side and check to see if the USB connection has been pulled away from the module.

c. **Push** the cable up into the module.



Still have the blue watermark on your Promethean screen?

You gave it your all ! You have done everything you can do to get your computer to connect to the board. The blue watermark is still present. **Please contact your Tech Coach** and we will get you problem corrected.